

SYSTEMATIC QUALITY

TrafficLED

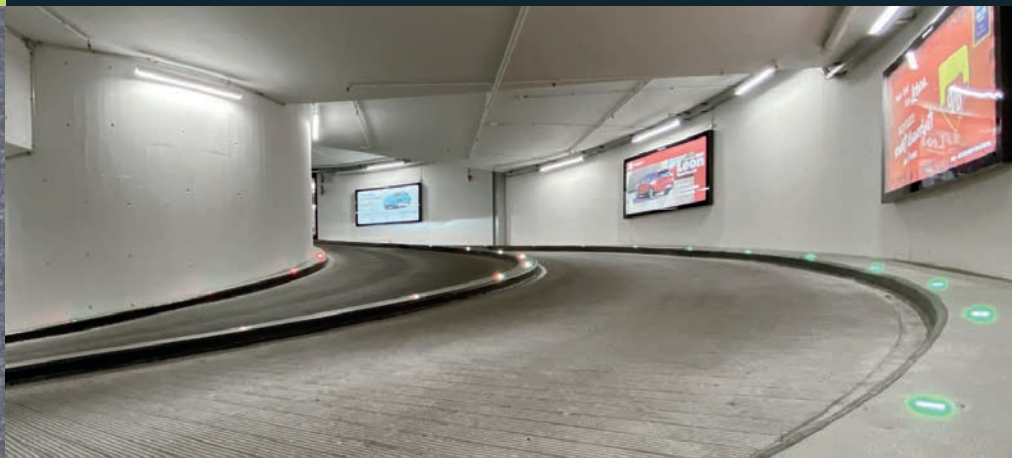

Product information



Introduction

Introduction



Page 3

Page 3

TrafficLED

Product/System

Technical data

Applications

Product range



Page 4

Pages 4-7

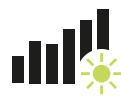

Page 5



Page 6



Page 7

Accessories

Control unit and remote control

Power pack

System components – mounting



Page 8

Pages 8-11



Page 9



Pages 10-11

LED guidance systems – for safe traffic routing



TrafficLED

Our product line of optical guidance devices is applicable in tunnels, roundabouts or on the road in general.

We have detailed information, documentation, certificates for our system MarkLED which we would be appreciate to send if you are interested.

Why optical guidance systems?

An optical guidance device improves recognition of lanes or obstacles, particularly during times of poor visibility (at night, fog, etc.) as well as vulnerable traffic areas such as tunnels, curves, roundabouts or traffic islands. The signals provide a very high degree of safety for traffic.

The system complies with current regulations (BAST Germany, FEDRO Switzerland e.g.), and are continous EMC-approved, which means, that the system functions with cables/wires and is non-inductive, so electromagnetic fields are excluded.

The wired systems are installed directly in the road surface. However, it is important that the installation area is not constantly driven over.

Our recess-mounted lamps are compatible with all GIFAS systems. They complement each other ideally and require the same system components, such as a control unit, feeder cable, etc.

All GIFAS systems can be dimmed across a continuous scale using the control unit or remote control.

Your benefits at GIFAS

- EMC-approved, no inductive interference
- quick and easy installation
- latest LED technology, very low power consumption
- vandal-proof, reinforced synthetic material/V4A Investment casting
- dimmable by control unit
- interoperable with all LED guidance systems
- modular construction, low-maintenance
- often set in systems in different applications
- thereby high product- and application know-how

Our services

- many years of know-how, experienced Project Manager
- individual advice, also on site
- large standard range, individual solutions possible
- expert advice on installation and bringing into service
- creating CAD documents, voltage drop calculations and tunnel disposals
- own service team with professional equipment and many years of know-how



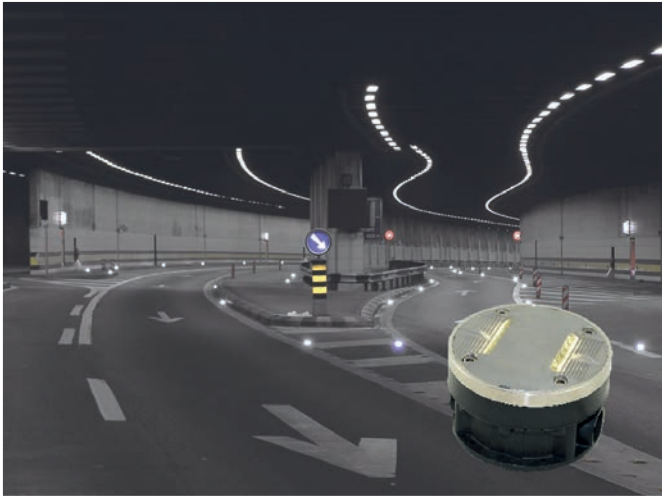

The permanent drive-over marker and warning lights with the latest LED technology!

By popular demand and as widely requested, we have developed a completely new light that covers a variety of needs. In particular, the main target during development was the ability to withstand constant traffic on streets, on squares, or in tunnels. It is also often used in the driveways of tunnels for improved visibility of the course of lane and pedestrians for improved active safety. Last, but not least, they can also be used to light roundabouts (also for heavy traffic).

Standard SN 640853 «Underfloor Marker Lights» served as the basis for development with the following specifications and requirements:

- drive-over marker lights that can withstand constant traffic and that cover the entire summer/winter temperature range (–30 to +75°C) and that can withstand mechanical stresses (40t truck)
- for safety reasons (slip hazard) matt, circular light
- protrude over road surface level max. 4.0mm
- resistant to sand, snow spikes and chains, street cleaning
- have no protruding corners or edges that could be touched by a snowplough
- surface and light emission areas are designed in such a way that as little dirt as possible is deposited
- waterproof, frostproof, and resistant to UV sunlight/chemicals/oil and road salt
- very good visibility in the dark, wet, and snow
- other applications: such as lane marking

The TrafficLED system complies with current regulations (e.g. BAST in Germany, FEDRO in Switzerland) and is one of the few EMC-tested systems, which means that the system works via wires, not induction.

TrafficLED module

The TrafficLED is connected with the system cable. It lights on both sides. Due to its modular structure with an upper and lower part, it is very easy to install.

The different modes of the TrafficLED, such as dimmable, blinking, flashing, etc., can be set via the controller.

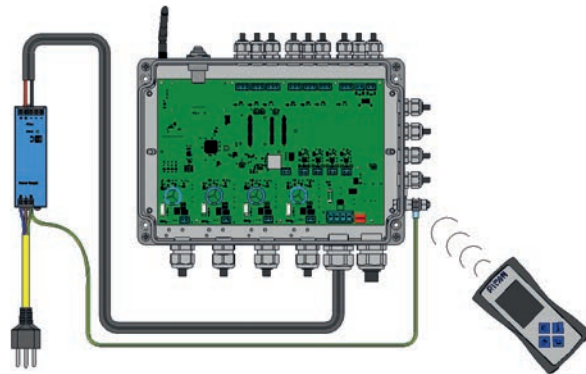

Control

The 4-channel control unit is used to control the GIFAS control units. It can be integrated into existing control cabinets or also as a „stand alone“ module.

Remote control

The remote control can be used for programming, operation and fault diagnosis. A single remote control can be used for multiple control units.

Standard cable

The system cable is made specifically for the GIFAS recessed lighting systems to meet its demands; the cable is halogen-free, mechanically reinforced, and may come briefly into contact with hot substances such as bitumen.

Junction box

The junction box is the control interface and the actual «front installation». Usually, the junction boxes are placed at the beginning or at the end of each line of TrafficLEDs, easy to assemble with prefabricated mounting tabs. We recommend our own standard junction boxes which meet all system requirements.

Product documentation

Installation instructions



TrafficLED - the system and the technology



Technical data

Double-sided with 6 LEDs on each side

Light colours:	white (5'600K), blue (470 nm), yellow (592 nm), orange (600 nm)
Luminous intensity:	30cd
Operating life LED:	L90/B10 100'000h (white)
Protection category:	IP68/IP69
Protection class:	III
Impact protection rating:	IK10
Operating voltage:	24VDC (range 18-44VDC)
Power consumption:	140mA @ 18-28VDC / 85mA @ 28-44VDC
Diameter:	120mm
Height:	80mm
Upper part:	chrome steel V4A
Lower section:	IXEF glass fiber reinforced polyarylamide, black
Height over road surface level:	4mm
Temperature resistance:	-30° C to +75° C
Drive-over resistance:	D400 according to DIN EN124

Certificates, reference lists on request.

The TrafficLED

- floor pit made out of special IXEF plastic
- stainless steel V4A upper section
- electronics completely encapsulated
- both sides fitted with LEDs
- Brightness of the lighting modules can be easily adjusted via controller unit and changed from the tunnel control centre via automatic light control or direct control system.

One-components TrafficLED

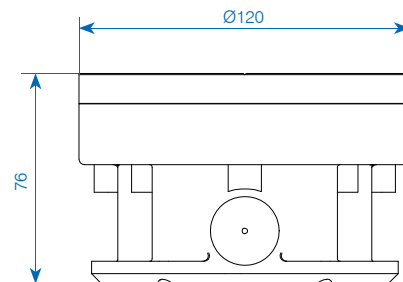
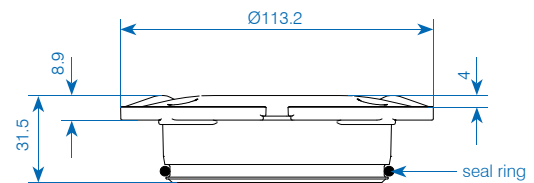

Scheme light emission

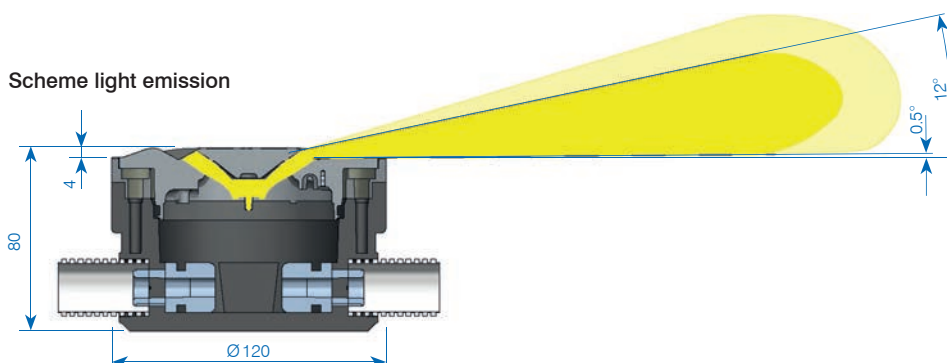



Railway station Flawil



TrafficLED



Street lighting Verbier



Roundabout Döttingen



Cityparking St. Gall

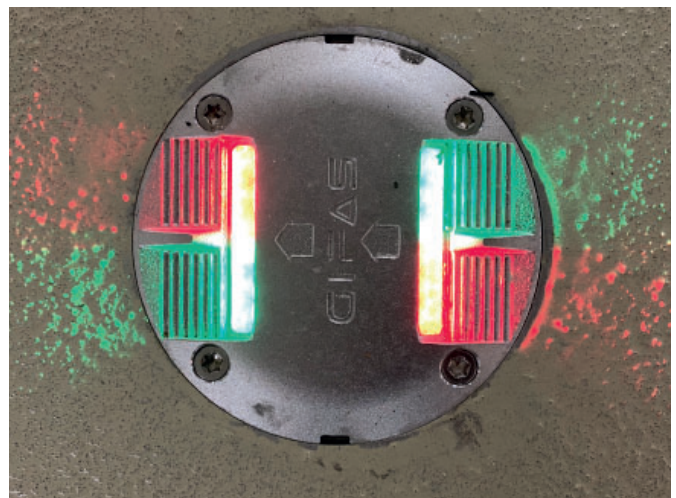

Cityparking St. Gall

Leveling support item no. 037712

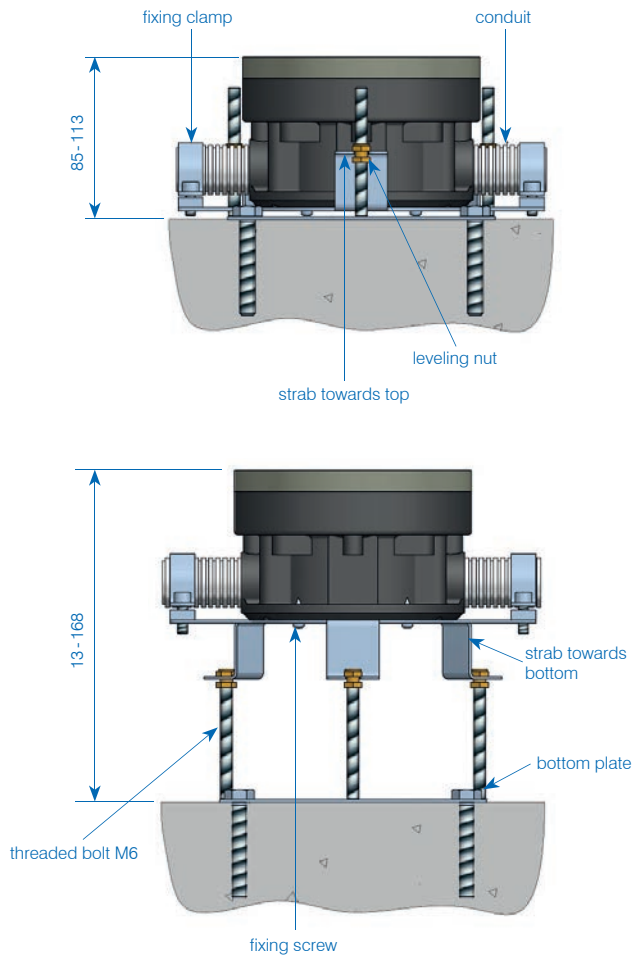

Item no. 142302



Item no. 140783



Item no. 141481

Assembling jig for TrafficLED

GIFAS provides a suitable assembling jig for installing the TrafficLED on loan. This makes it possible to adjust to the ground level exactly and to optimise the relocation of the component.



Item no.	Designation
143015	Assembling jig TrafficLED (on loan by GIFAS)



Item no.	Designation
139997	TrafficLED light module V4A, 18-28VDC, 140mA / 28-44VDC, 85mA, double-sided 6xLED blue, 470 nm
136194	TrafficLED light module V4A, 18-28VDC, 140mA / 28-44VDC, 85mA, double-sided 6xLED orange, 600-609 nm
138244	TrafficLED light module V4A, 18-28VDC, 140mA / 28-44VDC, 85mA, double-sided 6xLED white, 5'700K
213778	TrafficLED light module V4A, 18-28VDC, 140mA / 28-44VDC, 85mA, double-sided 6xLED weiss 5'700K, BAST switchable
153147	TrafficLED light module V4A, 18-28VDC, 80 mA / 28-44VDC, 50 mA, single-sided 6xLED blue, 470 nm
145604	TrafficLED light module V4A, 18-28VDC, 80 mA / 28-44VDC, 50 mA, single-sided 6xLED orange, 600-609 nm
860625	TrafficLED light module V4A, 18-28VDC, 80 mA / 28-44VDC, 50 mA, single-sided 6xLED yellow, 592-595 nm
146904	TrafficLED light module V4A, 18-28VDC, 80 mA / 28-44VDC, 50mA, single-sided 6xLED white, 5'700K
142301	TrafficLED lower section Ø 120x65 mm, 1 KV M16 (Ø 4-9) casing plastic anthracite with adjustment ring
142302	TrafficLED lower section Ø 120x65 mm, 2 KV M16 (Ø 4-9) casing plastic anthracite with adjustment ring
148704	TrafficLED lower section Ø 120x65 mm, 1 KV M16 (system cable flat), casing plastic anthracite with adjustment ring
148705	TrafficLED lower section Ø 120x65 mm, 2 KV M16 (system cable flat), casing plastic anthracite with adjustment ring
167067	TrafficLED lower section Ø 120x65 mm plastic IXEF 1521, 1 hose nipple M25
167065	TrafficLED lower section Ø 120x65 mm, 2 KV M16 (Ø 4-9) casing plastic anthracite with adjustment ring, with 2 hose nipple M25
215065	TrafficLED lower section 1xKV M16 (Ø 4-9) 1 hose nipple - special
212656	TrafficLED lower section Ø 120x65 mm, 2 KV M16 (Ø 4-9.5) casing plastic anthracite with adjustment ring, power distribution box mounted in the road surface
141481	TrafficLED blind cover V4A, Ø 113.2x27.5 mm incl. sealing and screw
140783	TrafficLED blind cover PP, Ø 113.8x4.9 mm plastic white (suitable for temporary cover only)
037712	Leveling support V2A complete to TrafficLED/CircLED range 85- 168 mm
173496	System cable TPE Traffic/CircLED black, halogen-free 2x2.5mm², Ø 8.2mm, strands: red, black

other versions on request

4-channel control unit

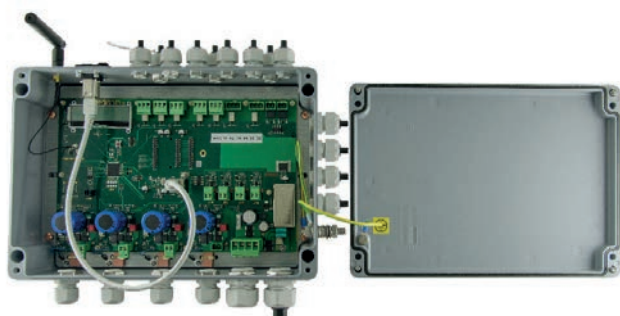

The control unit for all GIFAS systems is designed for 4 output lines. Each channel can be loaded with up to 10A.

- **Supply:** A 230VAC/24-48VDC power supply device with a nominal output current of 40 A is installed upstream from the control unit.
- **Error messages:** Each channel has a relay with SPDT (potential free) assigned to the signaling of error messages.
- **External blinking contacts:** By default, two external flashing signals (24-60VDC) can be connected and transferred to the outgoing lines (synchronisation with flashing signal).
- **Operating mode:** The control unit has 8 or 31 different modes of operation.
- **Failure rate:** By failure rate detection, the lights can be tested for their functionality. The control unit measures the total power consumption of the respective channel. If the power consumption drops to a preset value, the fault message can be detected via a changeover contact (potential-free).
- **Functions:** One of the following functions can be assigned to each channel in each mode:
 - Continuous lighting: 100%
 - Dimming: adjustable from 1-99%
 - Flash: adjustable from 0.1-9.9Hz
 - Lightning: adjustable from 1-99ms
 - Running light: running light direction, dimming 1-99%, Light duty cycle 100ms-10sek, delay in lighting 100ms-10sek, Switch-on delay 0-999sek, duty cycle 0-999sek
 - Off
- **Programming:** the control unit can be optionally parametrised and read out via the web interface or the optionally available radio programming unit.
 - Web interface: if the control unit is connected to the network via RJ45 Cat. 6a, all parameters can be set and read out via a web browser.
 - Radio programming unit: The parameters can also be set by the radio programming unit.

Technical data

Protection category:	IP65
Rated power max.:	1'920 VA
Input voltage:	18-48VDC
Supply current:	40A, 4 channels à 10A
Power supply:	external
Dimensions:	330×230×110mm

Remote control to 4-channel control unit



Programming device with menu guide for set-up, programming and status recognition of the control unit. Communication with the control unit occurs through radio.

All necessary functions can be set up and assigned through the menu structure. No special knowledge is required to operate it. The connection between the control unit and the programming device is bi-directional, i.e. the current settings can be transferred from one to the other.

The buttons «↑», «↓», «☒» and «✓» are used to navigate the system. The range is approx. 3m.

The menu is available in 4 languages: German, English, French and Italian.

Technical data

Material:	ABS
Protection category:	IP40
Protection class:	III
Radio frequency:	2.4-2.525 GHz
Operating voltage:	4.5VDC, 3 pcs. batteries type AAA
Life of battery:	> 1 year in standby mode
Dimensions (WxHxD):	73×140×32 mm
Colour:	graphite grey similar to RAL 7024

Item no.	Designation
860594	Control unit 4-channel IP65, 18-48VDC, 4×10A ready for installation in housing of cast aluminium 330×230×110mm, excl. power pack

Item no.	Designation
860460	Remote control complete for the control unit 4-channel

Power pack for control unit 4-channel



A 230VAC/24/36VDC power pack is installed upstream from the 4-channel control unit. The power pack is equipped with integrated protection against overloading and short-circuiting, with automatic or manual reset.

The power pack conforms to CEE regulations and also has UL and/or CSA approval.

Technical data

Protection category:	IP20 (with additional cover IP42)
Protection class:	I
Input voltage:	230 VAC (range 100 - 240 VAC)
Output voltage:	24/36VDC
Output current:	6.7/13.3/10/20 A
Connections primary:	screw terminals 4 mm ²
Connections secondary:	screw terminals 4 mm ²
Status display:	LED green
Installation:	quick fastening for DIN rail 35 mm
Dimensions (W×H×D):	- 24 VDC: 39×124×117 mm - 36 VDC: 65×124×127 mm

detailed datasheet of power pack available on request

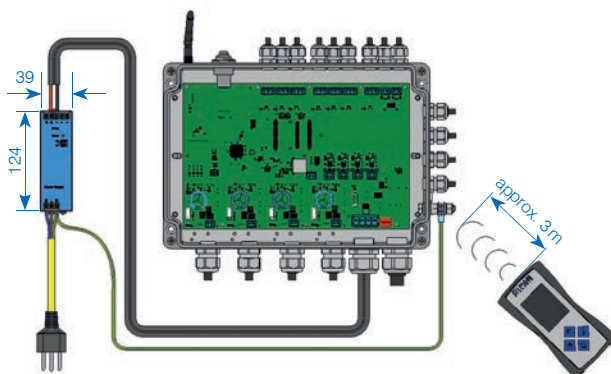

Item no.	Designation
163193	Power pack 230 VAC/24 VDC - 10 A/240 W 39×124×117 mm
136629	Power pack 230 VAC/24 VDC - 20 A/480 W 65×124×127 mm
192133	Power pack 230 VAC/36 VDC - 6.7 A/240 W 39×124×117 mm
244126	Power pack 230 VAC/36 VDC - 13.3 A/480 W 65×124×127 mm

Other versions on request

Cold conductor monitoring



The cold conductor monitoring is used for detecting defective installations or lights that are not connected. The monitoring is automatically activated as soon as the lights are switched off.

- **Feeding:** A power pack 230VAC/18-48VDC with a rated output current of max. 10A is connected upstream of the cold conductor monitoring. The level of the output voltage of the power pack depends on the marking light used in this case.
- **Fault signal:** The cold conductor monitoring has two relays with change-over contact (potential-free) to signal fault messages for voltage interruption (for example, failure of the power supply unit) and exceeding of the failure rate (for example defect in the control unit installation).
- **Functions:** In every cold conductor monitoring, the threshold for the max. failure rate detection can be set individually in percentage. The adjustment range is 10-70% and can be adjusted in 10% increments.
- **Programming:** Programming is done directly via the programming buttons on the control board or via the 4-channel control unit.

Technical data

Protection category:	IP66
Rated power max.:	480 VA
Input voltage:	18 - 48VDC
Supply current:	10 A
Power supply:	extern
Dimensions (W×H×D):	160×100×80 mm

Item no.	Designation
860603	Cold conductor monitoring, 18 - 48VDC, 10 A ready for installation in housing of cast aluminium 160×100×80 mm, excl. power pack

Fire-proof junction boxes

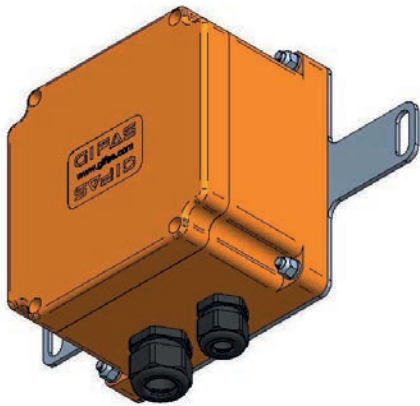

The safety cable must be connected from control center to the GIFAS system cable when connecting the signal units to the infrastructure. A special junction box is required for these connections. This can be installed in the cable trunks in the tunnel shoulder or at another suitable point. An E30/E60 junction box is usually required for this application. The size of junction box depends on the feed-in cable used as well as the number of outlets.

We will be pleased to advise you on a project-specific basis.

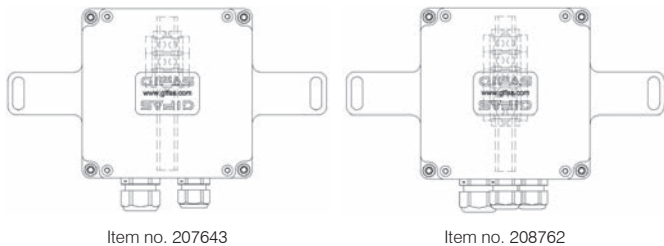

Item no.	Designation
207643	Junction box polyester FE180/E30 type 3018, orange 160×160×100 mm, 7×10 mm ² , IP66/68
208762	Junction box polyester FE180/E30 type 3018, orange 160×160×100 mm, 7×10 mm ² , IP66/68

System profile

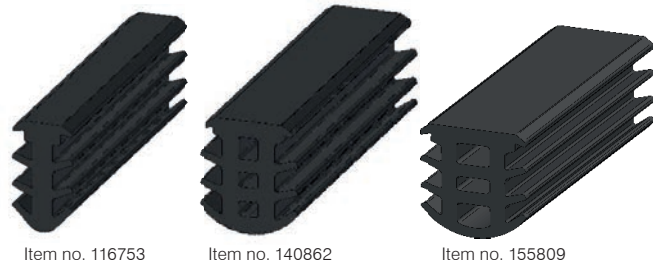

The milled groove of the optical guidance system must be sealed against environmental conditions. A simple and low-cost solution is to use the halogen-free GIFAS system profile made of EPDM. This is inserted in the slot. It is self-locking and available in three different widths. A stable and smooth slot with slot widths of 6 -15 mm is the prerequisite for use.

Technical data

Material properties: halogen-free, no corrosive and toxic gases
 Shore hardness A: 70° ±5%
 Special weight: 1.23 kg/l
 Elongation at break: 237% DIN 53504
 Breaking stress: 11.2 MPa DIN 53504

Item no. 116753
 Exterior dimensions: 9.3 mm × 17.1 mm
 Groove width: 6 - 8 mm
 Nominal section: 89 mm²
 Weight: 109 kg/km

Item no. 140862
 Exterior dimensions: 14.5 mm × 17.1 mm
 Groove width: 10 - 11.2 mm
 Nominal section: 146 mm²
 Weight: 177 kg/km

Item no. 155809
 Exterior dimensions: 17.35 mm × 17.5 mm
 Groove width: 12 - 15 mm
 Nominal section: 171 mm²
 Weight: 254 kg/km

Installation material

Protective hose

Depending on the type of installation, the system cable can also be conducted in a conduit (fluted, halogen-free).

We are glad to advise you for specific projects!



Item no.	Designation
035976	Conduit PP, Ø25/19 mm, flexible VE=100 m
128266	Protective hose PA6, Ø21.2/16.5 mm, flexible, VE=50 m UV resistance, operating range of temperature -40°C to 120°C, up to 150° for a short time 150°C

Item no.	Designation
116753	Joint profile EPDM 70° Shore, for groove 6-8 mm 9.3×17.1 mm, black
140862	Joint profile EPDM 70° Shore, for groove 10-11.2 mm 13×17.1 mm, black
155809	Joint profile EPDM 70° Shore, for groove 12-15 mm 17.35×17.5 mm, black

Joint sealing compound



The recommended system sealing compound is heated to 160°–180° C while being constantly mixed. The compound is applied using a spouted container or grouting lance. Excess compound must be removed by scraping once it has fully cooled.

Technical Data

Colour: black
 Form of delivery: 1 box with 24×cubes à 700 g
 Sealing temperature: 160° C - 180° C
 Weight per unit volume: 1.2g/cm³

Item no.	Designation
208907	Sealing compound TOK-Melt N2 (1 box with 24×cubes à 700g)

Lime Mortar

In order to install the lower part of the CircLED, you need lime mortar to fill in. For each lower part, you will need approximately 0.7l (~1.17kg).

Two-component mortar

if the luminaire is to be installed in an area of the road with constant heavy traffic, we recommend using a two-component repair and adhesive mortar such as Bücofix or similar.

Item no.	Designation
161035	Lime mortar Polifix Plus L, Container 25kg
184454	Bücofix SRV installation mortar, black (5kg pail)

Insulating gel

When not mounted on the wall, the box must be cast with removable sealing compound, e.g. Bluegel (Item no. 166534 1l container).



Item no.	Designation
166534	Insulating gel, solvent-free, VE=bottle à 1 litre 0.15 litres are required for each LED module (CircLED / TrafficLED)



GET IN TOUCH WITH US

News about the assortment and specific solutions can be found on our website:

www.gifas.ch

We reserve the right to make technical modifications. V 0823

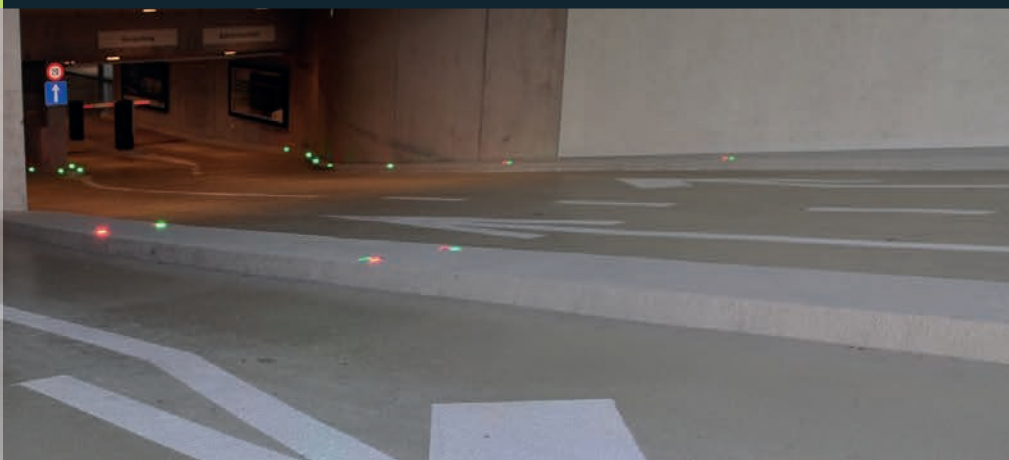

GIFAS
ELECTRIC

GIFAS-ELECTRIC GmbH
Dietrichstrasse 2
CH-9424 Rheineck

+41 71 886 44 44
+41 71 886 44 49
info@gifas.ch
www.gifas.ch